

# Fuller<sup>®</sup> Heavy-Duty Transmissions TRMT0951 EN-US

September 2007



*Powering Business Worldwide*

BACKED BY

**Roadranger**

SUPPORT

**This Page Intentionally Blank**

---

New Unit Exchange Program Overview ..... 2  
Introduction and Explanation ..... 3  
Unit Identification For Unit With Transmission Tag..... 4  
Transmission Interchange Section Header  
    Descriptions ..... 5  
Output Yokes (Chart C) ..... 7  
Shipping Weights ..... 13  
Transmission Oil Capacities ..... 14

## New Unit Exchange Program Overview

The Transmission Unit Exchange Program was created to make ordering Reman, New, or New Unit Exchange units a simple process. Please carefully read the details of this program before continuing into the interchange section of this book.

This book is organized in a way to help you order all the parts needed when ordering a Reman, New, or New Exchange Unit.

This book is divided into 15 sections:

1. Introduction and Explanation of Service Unit Exchange Program.
2. Unit identification – Locating Transmission Tag and Identifying Model Designation.
3. Unit identification – How to identify a unit when the identification tag is missing.
4. Options identification – How to identify various options the transmission may currently have, and whether or not a service unit for those options is available.
5. Clutch Housing identification – How to determine the part number of a clutch housing.
6. Transmission Interchange – How to determine the part number for Reman, New Unit, or New Exchange Unit by model.
7. Identification chart for RT-8609, RT-7608LL, RT/RTO-6610, or RT/RTO-6613 (Chart A) – To order the Reman version of these three models, identify the input shaft and front bearing cover.
8. Conversion Chart (Chart B) – When the current model is replaced by a Reman, New, or New Unit Exchange model that has a ratio or length change, refer to this section.
9. Recommended Stocking Guide – Clutch housings and/or shift bar housing assemblies.
10. Quick Reference Guide – To identify the model or "TA" number.
11. Accessories – To order various accessories for your Reman, New, or New Exchange Unit. This section lists part numbers for accessories by model.
12. Output Yoke Chart (Chart C) – Describes how to determine the yoke series, and part number.
13. Speedometer Parts – To order new speedo parts for your Reman, New, or New Exchange Unit. This section is divided into Mechanical and Magnetic sections.
14. Shipping weights.
15. Transmission Oil Capacities.

## Introduction and Explanation

This book contains information needed to cross reference most Fuller transmission models produced between the years 1985 and 1998. With this book you will have the ability to order and/or stock a Reman, New, or New Exchange Unit to meet customer requirements. This book groups all units together, based on speed and model, and it references SERVICE UNIT part numbers to be used when ordering or stocking service units.

In addition to offering a complete transmission interchange, this catalog contains information helpful in cases where it may be necessary to order other components when ordering a Reman, New, or New Exchange Unit. For example, in the Accessories Section you can look for a specific yoke application, push-in sensor rear bearing cover assembly, master valve with a generic medallion, generic medallion only, master valve with shift diagram medallion, shift diagram medallion only, or shift label only for ANY particular model. Other accessories covered are: service lever assemblies, Roadranger valve repair kits, and speedometer parts.

As stated above, there are three types of replacement units – Reman, New, or New Exchange. All Reman and New Exchange units have a CORE CHARGE. Please see publication APSL0419 for core and warranty details.

These units are “All-Makes” in nature, meaning they are ALL built with a Service Shift Bar Housing (with provisions for neutral light switch, reverse light switch, and breather), and a Service Rear Bearing Cover (with provisions for BOTH mechanical and magnetic pickups). Most service units are built standard with a 2" pull-type input shaft.

Most Service Units can be purchased with an integral oil pump option.

Please note that New and New Exchange Units are shipped WITHOUT a Clutch Housing. Reman units will continue to be shipped WITH a SAE #1 Clutch Housing (or SAE #2 for 6600 model series).

Information contained in this publication is also available on the Eaton web site: <http://truck.eaton.com> and on a CD-ROM called Specranger. Copies of Specranger can be obtained by contacting your local Eaton Roadranger Parts Marketing District Manager. For more information, call 1-800-826-HELP, (826-4357).

# Unit Identification For Unit With Transmission Tag

## Unit Identification For Unit With Transmission Tag

The first step in the process of ordering a service unit is determining the current model. There are two ways to do this. The first way is to locate the tag on the side of the transmission and identify its model designation. The second way is, if the unit does not have a tag follow the transmission identification chart in the next section to determine the model. When the current model is identified, proceed to Transmission Interchange Section.

## Locating Transmission Tag and Identifying Model Designation

Transmission model designation (i.e. RT-12609A), and other transmission identification information, are stamped on the transmission tag. To identify the transmission model designation (nomenclature), locate the tag on the transmission and then locate the model designation number as shown.

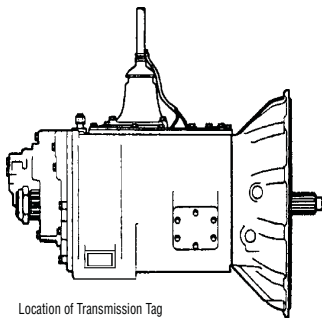

### Heavy Duty Models

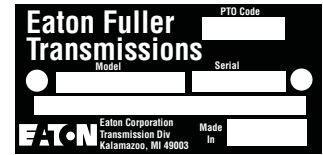
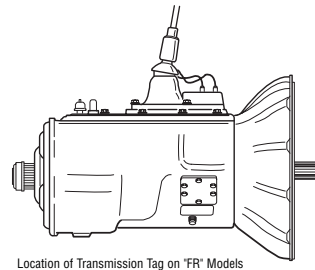
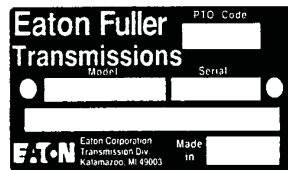

## Using Model Designation or Nomenclature

The model designation or nomenclature assigned to a transmission model provides information concerning transmission torque capacity, forward speeds, ratio set, shift bar housing and other provisions and options. Use the following guidelines to identify your transmission model designation.

### Heavy Duty Transmission - Nomenclature

Eaton® Fuller® Model Designation Prefix  
See options below:

Prefix	Definition
T	Twin Countershaft
TX	w/Overdrive
RT	Roadranger® Twin Countershaft
RTF	w/ Forward Shift Bar Housing
RTO	w/ Overdrive
RTOF	w/ Overdrive and Forward Shift Bar Housing
RTX	w/ Overdrive and Direct Shift Pattern
RTXF	w/ Overdrive, Direct Shift Pattern and Forward Shift Bar Housing
FR	Fuller® Roadranger® Twin Countershaft
FRF	w/ Forward Shift Bar Housing
FRO	w/ Overdrive
EROF	w/ Overdrive and Forward Shift Bar Housing

**R T O - 1 1 9 0 9 M L L**

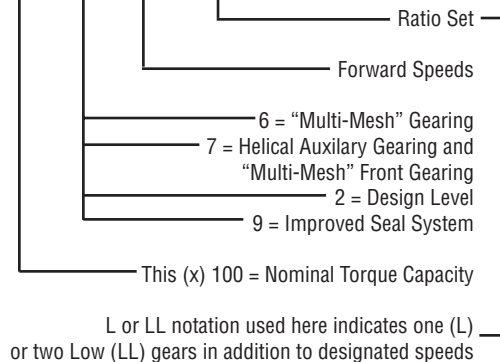

### “Super” Transmissions

**R T L O F\* - 1 4 6 1 0 A**



\* Transmission nomenclature may indicate a Standard (RTLO) or Forward (RTLOF) Mounted Shift Tower.

## Transmission Interchange Section Header Descriptions

Before continuing into the main interchange section of this catalog, read below for header explanation.

### Model:

Find your transmission model on the metal serial tag, please refer to page 4 for locating the serial tag. If the tag is missing, see the Transmission Identification Chart to determine the transmission model. Many options are not identified in the model number of the transmission. For proper identification of which options your transmission may have, please see the Options Chart.

NOTE: Models listed in the MODEL column that have an "\*" after the model listing are NOT eligible for a core return credit.

### Reman Unit Model Designation:

Reman models currently available.

### Reman Unit Part Number Without Integral Oil Pump:

Reman transmission models include an SAE #1 standard clutch housing, except the 6600 series, which includes an SAE #2 standard clutch housing. Reman units purchased require a core return (Except in cases where an "\*" appears beside the Model listed, means NO CORE VALUE. For core and warranty details, please refer to publication #ASPL0419.

Many Fuller Transmissions are built today with an integral oil pump. This option is not indicated on the original transmission's identification plate. Please see the Options Chart to determine whether an integral oil pump is present. Integral oil pump options for all Reman, New and New Exchange Units are indicated by a suffix of "11" – indicating NO PUMP, or "12" – indicating PUMP. Part numbers for Reman transmissions are all followed by an "R". For example: the Reman part number for an RTX-12609A without an integral oil pump would be TA-830-11R.

### Reman Unit Part Number With Integral Oil Pump:

Reman transmission models include an SAE #1 standard clutch housing, except the 6600 series, which includes an SAE #2 standard clutch housing. Reman units purchased require a core return (Except in cases where an "\*" appears beside the Model listed, means NO CORE VALUE. For core and warranty details, please refer to publication #ASPL0419.

As an extra cost option, an integral oil pump can be ordered on most Reman transmission models. Many Fuller Transmissions are built today with an integral oil pump. This option is not indicated on the original transmission's identification plate. Please see the Options Chart to determine whether an integral oil pump is present. Integral oil pump options for all Reman, Unit Exchange and New Service Units are indicated by a suffix of "11" – indicating NO PUMP, or "12" – indicating PUMP. Part numbers for Reman transmissions are all followed by an "R". For example: the Reman part number for an RTX-12609A with an integral oil pump would be TA-830-12R.

### Service Unit Model Designation:

This is the list of New Service models currently available in production.

### Service Unit Part Number Without Integral Oil Pump:

New Service Units are shipped **without** clutch housings. To determine the proper clutch housing to order, please refer to the Clutch Housing Identification Section. These units include a service rear bearing cover (with provisions for both mechanical AND magnetic speedometer pickups), and service shift bar housing (with provisions for neutral light switch, reverse light switch, and breather). As an extra cost option, an integral oil pump can be ordered on most New, and New Exchange transmission models. Many Fuller Transmissions are built today with an integral oil pump. This option is not indicated on the original transmission's identification plate. Please see the Options Chart to determine whether an integral oil pump is present. For warranty details, please refer to publication #ASPL0419. Integral oil pump options for all Reman, Unit Exchange, and New Service Units are indicated by a suffix of "11" – indicating NO PUMP, or "12" – indicating PUMP. For example: the New Service Unit part number for an RTX-12609A without an integral oil pump would be TA-830-11.

**Service Unit Part Number With Integral Oil Pump:**

New Service Units are shipped **without** clutch housings. To determine the proper clutch housing to order, please refer to the Clutch Housing Identification Section. These units include a service rear bearing cover (with provisions for both mechanical AND magnetic speedometer pickups), and service shift bar housing (with provisions for neutral light switch, reverse light switch, and breather). As an extra cost option, an integral oil pump can be ordered on most New, and New Exchange transmission models. Many Fuller Transmissions are built today with an integral oil pump. This option is not indicated on the original transmission's identification plate. Please see the Options Chart to determine whether an integral oil pump is present. For warranty details, please refer to publication #ASPL0419. Integral oil pump options for all Reman, Unit Exchange, and New Service Units are indicated by a suffix of "11" – indicating NO PUMP, or "12" – indicating PUMP. For example: the New Service Unit part number for an RTX-12609A with an integral oil pump would be TA-830-12.

**Service Unit Exchange Part Number Without Integral Oil Pump:**

New Service Units are shipped without clutch housings. To determine the proper clutch housing to order, please refer to the Clutch Housing Identification Section. These units include a service rear bearing cover (with provisions for both mechanical AND magnetic speedometer pickups), and service shift bar housing (with provisions for neutral light switch, reverse light switch, and breather). As an extra cost option, an integral oil pump can be ordered on most New and New Exchange transmission models. Many Fuller Transmissions are built today with an integral oil pump. This option is not indicated on the original transmission's identification plate. Please see the Options Chart to determine whether an integral oil pump is present. A core value for new service units is the amount you will be billed if an acceptable core is not returned against the purchase of a New Exchange Transmission (Except in cases where an "\*" appears beside the Model listed, means NO CORE VALUE). For core and warranty details, please refer to publication #ASPL0419. Integral oil pump options for all Reman, Unit Exchange, and New Service Units are indicated by a suffix of "11" -- indicating NO PUMP, or "12" – indicating PUMP. Part numbers for Service Unit Exchange transmissions are all followed by an "X". For example: the Service Unit Exchange part number for an RTX-12609A without an integral oil pump would be TA-830-11X.

**Service Unit Exchange Part Number With Integral Oil Pump:**

New Service Units are shipped without clutch housings. To determine the proper clutch housing to order, please refer to the Clutch Housing Identification Section. These units include a service rear bearing cover (with provisions for both mechanical AND magnetic speedometer pickups), and service shift bar housing (with provisions for neutral light switch, reverse light switch, and breather). As an extra cost option, an integral oil pump can be ordered on most New and New Exchange transmission models. Many Fuller Transmissions are built today with an integral oil pump. This option is not indicated on the original transmission's identification plate. Please see the Options Chart to determine whether an integral oil pump is present. A core value for new service units is the amount you will be billed if an acceptable core is not returned against the purchase of a New Exchange Transmission (Except in cases where an "\*" appears beside the Model listed, means NO CORE VALUE). For core and warranty details, please refer to publication #ASPL0419. Integral oil pump options for all Reman, Unit Exchange, and New Service Units are indicated by a suffix of "11" – indicating NO PUMP, or "12" – indicating PUMP. Part numbers for Service Unit Exchange transmissions are all followed by an "X". For example: the Service Unit Exchange part number for an RTX-12609A with an integral oil pump would be TA-830-12X.

**Is Service Unit Same Length and PTO Speed As Model?:**

If your model supersedes to a different new or new exchange model, please check this column to verify if the new model will not have any fit-up differences with regard to overall unit length and whether or not there is any differences in the PTO speed. If "NO", please see the Conversion Chart B for details.

**See Conversion Chart?:**

If "YES", then the new service unit will have ratio changes. Please refer to the Conversion Chart B (conversion chart B is arranged by model and speed). The ratios for both the model that is being replaced and the service unit are listed for comparison. Changing ratios can affect startability, road speed, and steps between gears. Also listed are weights, overall lengths, and PTO speeds as a % of engine speed.



## Output Yokes (Chart C)

To determine the proper part number to order for a new yoke, the following information is required.

1. What STYLE? – Half round, Full round, or Flange (See Figure 1)
2. What SERIES? – To determine series, take 3 measurements (See Figure 2) and apply them to Table 1 below.
3. What APPLICATION NUMBER? – To determine application number, refer back to the accessories section. Find the model you are fitting with the yoke and locate the number in the column with the heading “Model Yoke Application”.
4. Once Style, Series and Application Number have been determined, continue to Chart C to locate the corresponding application number section. Within each application number section you can order a yoke either with or without a slinger, based on style, series, tapped, or non-tapped holes. The current seal system utilizes the yoke with slinger design. All units shipped are to this design level (yoke w/slinger).

**Figure 1**

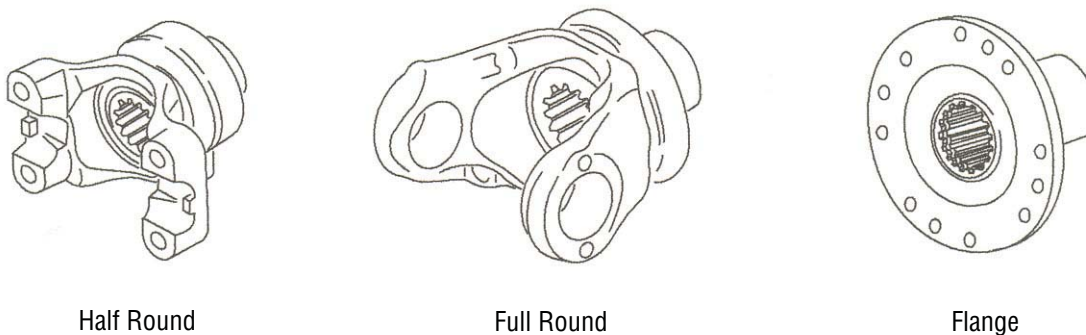

**Figure 2**

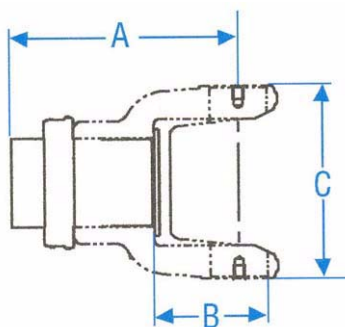

**Table 1**

**Dimensions in Inches**

Dimension A	4-3/4	4-15/16	5-3/16	5-1/4	5-1/4	5-1/4
Dimension B	1-7/8	1-7/8	1-15/16	1-15/16	1-15/16	1-15/16
Dimension C	5-5/16	5-5/16	6-1/16	6-1/16	7	7-1/2
Yoke Series	1610	1610	1710	1710	1760	1810
Dimension A	5-5/16	5-7/16	6	6-1/8	6-3/16	6-3/8
Dimension B	1-7/8	1-15/16	1-7/8	1-15/16	1-7/8	1-15/16
Dimension C	5-5/16	6-1/16	5-5/16	6-1/16	5-5/16	6-1/16

## Output Yokes (Chart C)

### APPLICATION "1"

MAJOR DIAMETER 2.500 - 10 SPLINE - HUB DIAMETER AT OIL SEAL 3.750								
Half Round	Full Round	Flange	Tapped Holes	Non-Tapped Holes	Yoke Series	Notes	Part Number Without Slinger	Part Number With Slinger
	X			X	1710		86717	A-5064
X			X		1710	1/2 - 20 TAPPED HOLES	86749	A-5190
		X		X	1650/1710		86761	A-5252
	X			X	1760		86716	A-5061
		X		X	1760		86760	A-5251
X			X		1760	1/2 - 20 TAPPED HOLES	86762	A-5262
	X			X	1810		86718	A-5079
X			X		1810	1/2 - 20 TAPPED HOLES	86769	A-5412

T11607A	RTX11609A	RTX12609R	RT7608LL	RTX11710B	RT13710B	RTLO12713A
T11607B	RTX11609B	RT12709H	RTO11608LL	RTX11710C	RTX13710B	RT11615
RT11608	RTX11609P	RTX12709H	RTX11608LL	RT12610	RTX13710C	RTO11615
RT8608L	RTX11609R	RT13609A	RTO11708LL	RTLO12610B	RT6613	RTX11615
RT8709B	RTX11709H	RTX13609A	RTX11708LL	RTO12610	RTO6613	RT11715
RT11609A	RTO12609A	RTX13609B	RT11610	RTX12610	RT11613	RTO11715
RTO11609A	RTO12609B	RTX13609P	RTLO11610B	RT12710B	RTO11613	RTX11715
RTO11609B	RTX12609A	RTX13609R	RTO11610	RTX12710B	RTO011613	
RT11709H	RTX12609B	RT13709H	RTX11610	RTX12710C	RTO0F11613	
RT12609A	RTX12609P	RTX13709H	RT11710B	RTLO13610B	RTO11813	

## Output Yokes (Chart C)

### APPLICATION “2”

MAJOR DIAMETER 2.750 - 10 SPLINE - HUB DIAMETER AT OIL SEAL 3.750								
Half Round	Full Round	Flange	Tapped Holes	Non-Tapped Holes	Yoke Series	Notes	Part Number Without Slinger	Part Number With Slinger
	X			X	1710		86719	A-5080
X			X		1710	1/2 - 20 TAPPED HOLES	86765	A-5291
	X			X	1760		86720	A-5081
		X		X	1760/1810		86728	A-5082
X			X		1760	1/2 - 20 TAPPED HOLES	86771	A-5416
	X			X	1810		86721	A-5073
X			X		1810	1/2 - 20 TAPPED HOLES	86770	A-5413
AT1202	RTX14609P	RTLO14610B	RTX16710C	RTO15813	RTO15715			
RTO11607L	RTX14609R	RTO14610	RTLO18610B	RTLO16713A	RTX15715			
RT14608	RT14709H	RTX14610	RTLOF18610B	RT14615	RTLO14618A			
RTO11607LL	RTX14709H	RTX14610A	RT14613	RTO14615	RTLO14718B			
RTO11707DLL	RTX16709B	RT14710B	RTLO14613B	RTX14615	RTO15618			
RTO11707LL	RTX16709H	RTX14710B	RTO14613	RT14715	RTLO16618A			
RTO13707MLL	RTO14608LL	RTX14710C	RT0014613	RTO14715	RTLO16718B			
RT14609A	RTX14608LL	RTLO15610B	RT00F14613	RTX14715	RTLO18718B			
RTO14609A	RTO14708LL	RTX15710B	RTLO14713A	RT15615				
RTO14609B	RTX14708LL	RTX15710C	RTO14813	RTO15615				
RTX14609A	RT14610	RTLO16610B	RT15613	RTX15615				
RTX14609B	RTLO14610A	RTX16710B	RTO15613	RT15715				
NOTE: Older generations of the above models used a yoke or flange with a 3.500 diameter hub at seal area. For these applications, use 20807 or equivalent seal with 3.750 diameter hub on yoke or flange listed above.								

## Output Yokes (Chart C)

### APPLICATION “3”

MAJOR DIAMETER 2.250 - 10 SPLINE - HUB DIAMETER AT OIL SEAL 3.500 - ALSO SEE APP. “8”									
Half Round	Full Round	Flange	Tapped Holes	Non-Tapped Holes	Yoke Series	Notes	Part Number Without Slinger	Part Number With Slinger	
		X		X	1610		86734	N/A	
	X			X	1610		86757	N/A	
	X			X	1710		86733	N/A	
		X		X	1710		86735	N/A	
X			X		1710	1/2 - 20 TAPPED HOLES	5505506	N/A	
	X			X	1760		86724	N/A	
2A92		T11605B		T11605D		T11605M		RT8609A	RT06610
T11605A		T11605C		T11605F		RT6609A		RT6610	

### APPLICATION “4”

MAJOR DIAMETER 2.750 - 10 SPLINE - HUB NOT USED FOR SEAL - SPACER REQUIRED								
Half Round	Full Round	Flange	Tapped Holes	Non-Tapped Holes	Yoke Series	Notes	Part Number Without Slinger	Part Number With Slinger
X			X		1760	1/2 - 20 TAPPED HOLES	86604	N/A
X			X		1810	1/2 - 20 TAPPED HOLES	86605	N/A
RTO11709MLL								
RTO14709MLL								

### APPLICATION “5”

MAJOR DIAMETER 2.343 - 45T INVOLUTE SPLINE - HUB DIAMETER AT OIL SEAL 3.750								
Half Round	Full Round	Flange	Tapped Holes	Non-Tapped Holes	Yoke Series	Notes	Part Number Without Slinger	Part Number With Slinger
X			X		1610	1/2 - 20 TAPPED HOLES	86763	A-5263
	X			X	1710		86737	A-5122
X			X		1710	1/2 - 20 TAPPED HOLES	86764	A-5264
X			X		1760	1/2 - 20 TAPPED HOLES	5505521	A-5451
T8607A		T8607B		TX8607B				

**APPLICATION “6”**

MAJOR DIAMETER 2.544 - 49T INVOLUTE SPLINE - HUB DIAMETER AT OIL SEAL 3.750								
Half Round	Full Round	Flange	Tapped Holes	Non-Tapped Holes	Yoke Series	Notes	Part Number Without Slinger	Part Number With Slinger
		X		X	1710		86738	A-5123
	X			X	1710		86741	A-5126
X			X		1710	1/2 - 20 TAPPED HOLES	86775	A-5436
	X			X	1760		86740	A-5125
	X			X	1810		86742	A-5127
X			X		1810	1/2 - 20 TAPPED HOLES	86774	A-5435
T-14607								

**APPLICATION “7”**

MAJOR DIAMETER 2.250 - 10 SPLINE - HUB DIAMETER AT OIL SEAL 3.750								
Half Round	Full Round	Flange	Tapped Holes	Non-Tapped Holes	Yoke Series	Notes	Part Number Without Slinger	Part Number With Slinger
X			X		1610	1/2 - 20 TAPPED HOLES	86747	A-5191
X			X		1710	1/2 - 20 TAPPED HOLES	86748	A-5192
		X		X	1710		86753	A-5268
X			X		1760	1/2 - 20 TAPPED HOLES	86772	A-5422
2A92		T14607A	T14607B		TX14607B		RT6609A	RT8609A
RT6610		RT06610						

## Output Yokes (Chart C)

### APPLICATION "8"

MAJOR DIAMETER 2.750 - 54T INVOLUTE SPLINE - NO SEAL								
Half Round	Full Round	Flange	Tapped Holes	Non-Tapped Holes	Yoke Series	Notes	Part Number Without Slinger	Part Number With Slinger
X			X		1710	1/2 - 20 TAPPED HOLES	5505543	
	X				1710		5505544	
X			X		1760	1/2 - 20 TAPPED HOLES	5505545	
	X				1760		5505546	
X			X		1810	1/2 - 20 TAPPED HOLES	5505547	
	X				1810		5505548	
X			X		RPL25	1/2 - 20 TAPPED HOLES	5505553	
X			X		SPL170	M12 x 1.25 TAPPED HOLES	5505571	
X			X		SPL250	M12 x 1.25 TAPPED HOLES	5505572	
X			X		92N	1/2 - 20 TAPPED HOLES	5505578	

RT8908LL	FRO12210B	FR14210B	FRO15210B	RT016210C	RTLO16913A	RTLO14918B
RTF8908LL	FROF12210B	FRF14210B	FROF15210B	RTOF16210C	RTLOF16913A	RTLOF14918B
RT011908LL	FRO12210C	FRO14210C	FRO15210C	RT011909MLL	RTLO18913A	RTLO16918B
RTOF11908LL	FROF12210C	FROF14210C	FROF15210C	RTOF11909MLL	RTLOF18913A	RTLOF16918B
RT014908LL	FR13210B	RT14210B	RT015210C	RT014909MLL	RT14915	RTLO18918B
RTOF14908LL	FRF13210B	RTF14210B	RTOF15210C	RTOF14909MLL	RTF14915	RTLOF18918B
RT016908LL	FRO13210B	RT014210C	FRO16210B	RTLO12913A	RT014915	RTLO20918B
RTOF16908LL	FROF13210B	RTOF14210C	FROF16210B	RTLOF12913A	RTOF14915	RTLOF20918B
FR12210B	FRO13210C	FR15210B	FRO16210C	RTLO14913A	RT016915	
FRF12210B	FROF13210C	FRF15210B	FROF16210C	RTLOF14913A	RTOF16915	

## Shipping Weights

Model	Weight With No Clutch Housing	Weight With Cast Iron Housing	Weight With Aluminum Clutch Housing
14607	575	643	596
7608	597	665	618
8608	583	651	604
8908	690	758	711
11708	675	743	696
11908	690	758	711
14708	690	758	711
14908	690	758	711
16908	690	758	711
6609	376	444	397
8609	376	444	397
8709	581	649	602
12609	583	651	604
12709	583	651	604
13609	588	656	609
13709	588	656	609
14609	607	675	628
14709	607	675	628
16709	617	685	638
12210	592	660	613
12610	625	693	646
12710	606	674	627
13210	592	660	613
13610	625	693	646
13710	611	679	632
14210	592	660	613
14610	630	698	651
14710	624	692	645

Model	Weight With No Clutch Housing	Weight With Cast Iron Housing	Weight With Aluminum Clutch Housing
15210	602	670	623
16210	602	670	623
16610	630	698	651
16710	634	702	655
18610	630	698	651
11709MLL	671	739	692
11909MLL	671	739	692
14709MLL	673	741	694
14909MLL	673	741	694
12713	714	782	735
12913	714	782	735
14713	714	782	735
14913	714	782	735
16713	716	784	737
16913	716	784	737
18913	716	784	737
14715	696	764	717
14915	696	764	717
15715	696	764	717
16915	696	764	717
14718	716	784	737
14918	716	784	737
16718	716	784	737
16918	716	784	737
18718	716	784	737
18918	716	784	737
20918	716	784	737

ADD 50 POUNDS FOR SHIPPING MATERIALS

All weights are approximate

## Transmission Oil Capacities

**Note:** These values are approximate—always use the fill hole as the final reference.

### Eaton® Fuller® Transmission Oil Capacities

Twin Countershaft Models	Pints	Liters
<b>5 SPEEDS</b>		
905	22	10
11605	22	10
<b>6 SPEEDS</b>		
955AL	25	12
906	26	12
1056AA	29	14
11606	26	12
<b>7 SPEEDS</b>		
955ALL	28	13
8607	36	17
11607	36	17
14607	37	17
<b>8 SPEEDS</b>		
1157DL	27	13
11607L	28	13
9508	25	12
11608	26	12
14608	28	13
<b>9 SPEEDS</b>		
9509	25	12
11509	25	12
12509	25	12
1157DLL	29	14
6609	12	6
8609	15	7
8608L	27	13

Twin Countershaft Models	Pints	Liters
<b>9 SPEEDS – CONTINUED</b>		
11607LL	31	15
11707LL	28	13
11707DLL	28	13
13707DLL	28	13
13707MLL	28	13
11609	27	13
12609	27	13
13609	27	13
14609	27	13
11709	27	13
12709	27	13
13709	27	13
14709	27	13
16709	27	13
<b>10 SPEEDS</b>		
958LL	28	13
1258LL	28	13
7608LL	19.5	9
11608LL	29	14
14608LL	29	13
11708LL	28	13
14708LL	29	14
8908LL	28	13
11908LL	28	13
14908LL	28	13
16908LL	28	13
12510	25	12
610	12	6
6610	12	6
910	25	12
1110	25	12



# Transmission Oil Capacities

Twin Countershaft Models	Pints	Liters
10 SPEEDS – CONTINUED		
11610	26	12
12610	26	12
14610	26	12
RTLO-11610	28	13
RTLO-12610	28	13
RTLO-13610	28	13
RTLO-14610	28	13
RTLO-15610	28	13
RTLO-16610	28	13
11710	26	12
12710	26	12
13710	26	12
14710	26	12
15710	26	12
16710	26	12
FR-11210	23.5	11
FR-12210	23.5	11
FR-13210	23.5	11
FR-14210	23.5	11
FR-15210	23.5	11
FR-16210	23.5	11
11 SPEEDS		
11709MLL	28	13
14709MLL	28	13
11909MLL	28	13
14909MLL	28	13
13 SPEEDS		
12513	27	13
613	16	8
6613	16	8
9513	27	13

Twin Countershaft Models	Pints	Liters
13 SPEEDS – CONTINUED		
11613	29	14
14613	29	14
15613	29	14
RTLO-14613	28	13
RTLO-12713	28	13
RTLO-14713	28	13
RTLO-16713	28	13
RTLO-18913	28	13
15 SPEEDS		
915	28	13
12515	28	13
11615	28	13
14615	30	14
15615	30	14
11715	28	13
14715	28	13
15715	28	13
14915	28	13
16915	28	13
18 SPEEDS		
RTLO-14618	28	13
RTLO-16618	28	13
RTLO-14718	28	13
RTLO-16718	28	13
RTLO-18718	28	13
RTLO-20918	28	13

Copyright Eaton, 2013

Eaton hereby grant their customers, vendors, or distributors permission to freely copy, reproduce and/or distribute this document in printed format. It may be copied only in its entirety without any changes or modifications. THIS INFORMATION IS NOT INTENDED FOR SALE OR RESALE, AND THIS NOTICE MUST REMAIN ON ALL COPIES.

**Note:** Features and specifications listed in this document are subject to change without notice and represent the maximum capabilities of the software and products with all options installed. Although every attempt has been made to ensure the accuracy of information contained within, Eaton makes no representation about the completeness, correctness or accuracy and assumes no responsibility for any errors or omissions. Features and functionality may vary depending on selected options.

**For spec'ing or service assistance, call 1-800-826-HELP (4357) or visit [www.eaton.com/roadranger](http://www.eaton.com/roadranger). In Mexico, call 001-800-826-4357.**

Roadranger: Eaton and trusted partners providing the best products and services in the industry, ensuring more time on the road.

**Eaton**

Vehicle Group  
P.O. Box 4013  
Kalamazoo, MI 49003 USA  
800-826-HELP (4357)  
[www.eaton.com/roadranger](http://www.eaton.com/roadranger)

Printed in USA