

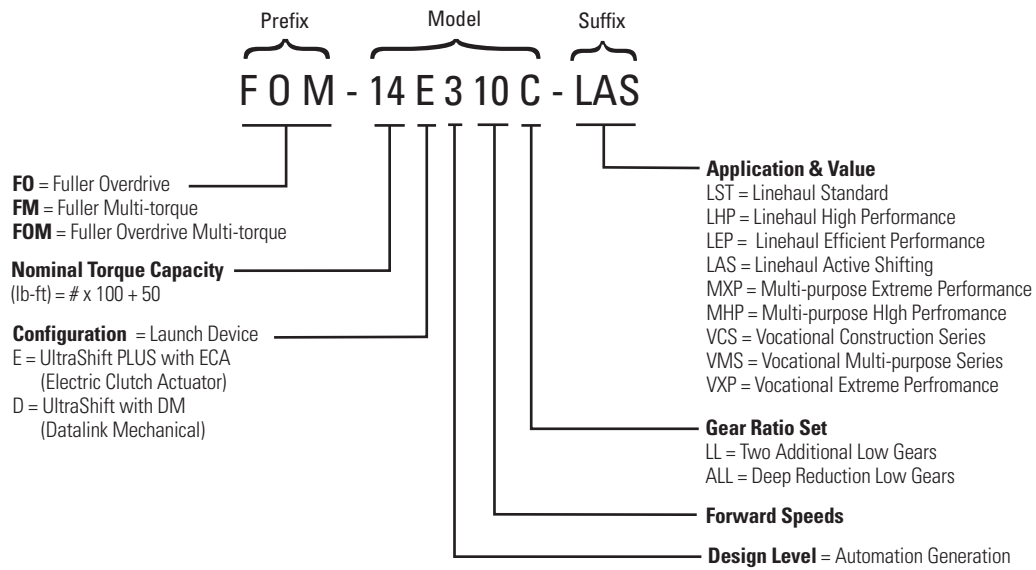

Automated Transmissions – Heavy-Duty

UltraShift & UltraShift PLUS (new nomenclature rules)

Marketing Name: Fuller UltraShift PLUS Linehaul Active Shifting (LAS)



UltraShift & AutoShift (old nomenclature rules)

Marketing Name: AutoShift 18 Speed RTLO-18918A-AS3

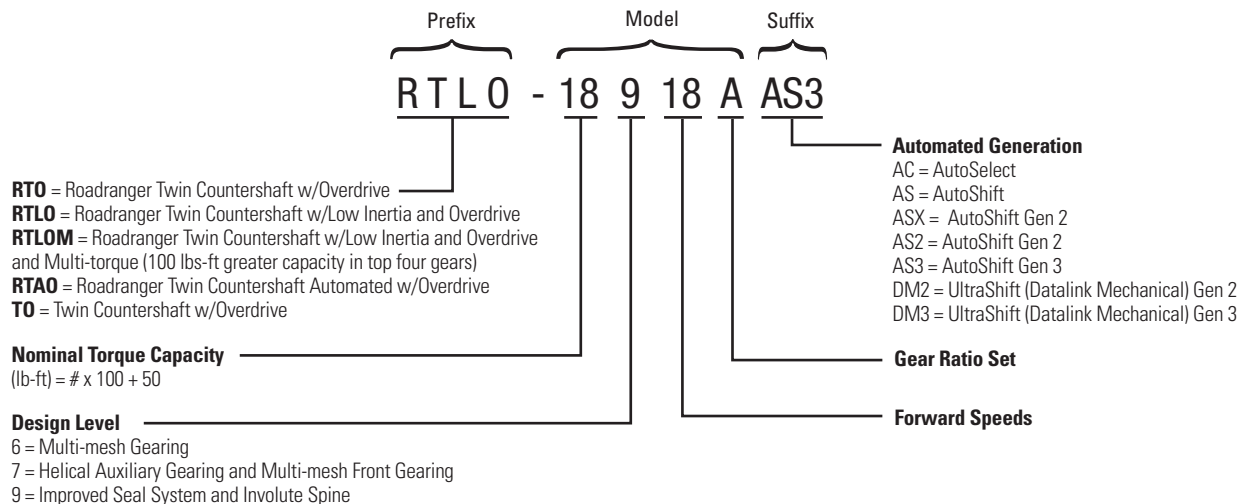

Automated Transmissions – Medium-Duty

Medium-Duty UltraShift & AutoShift (old nomenclature rules)

Marketing Name: Fuller UltraShift Highway Value (HV)

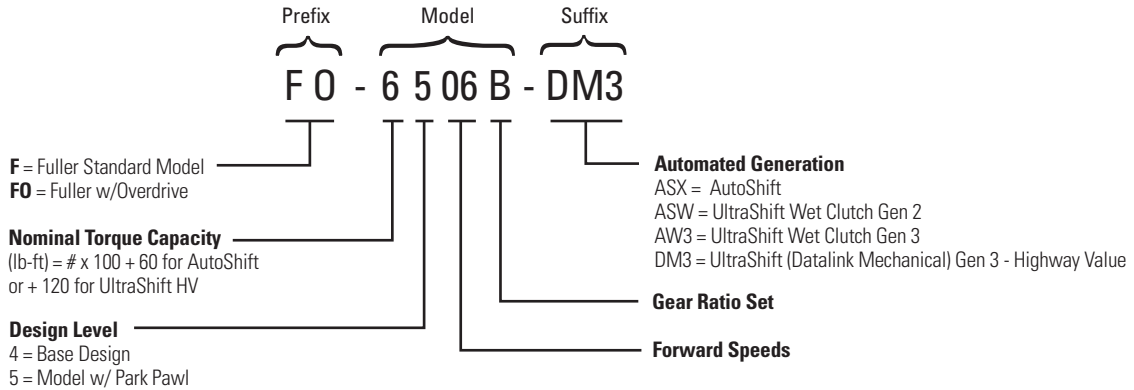

Manual Transmissions – Heavy-Duty

(old nomenclature rules)

Marketing Name: Fuller 9-Speed Manual Transmission

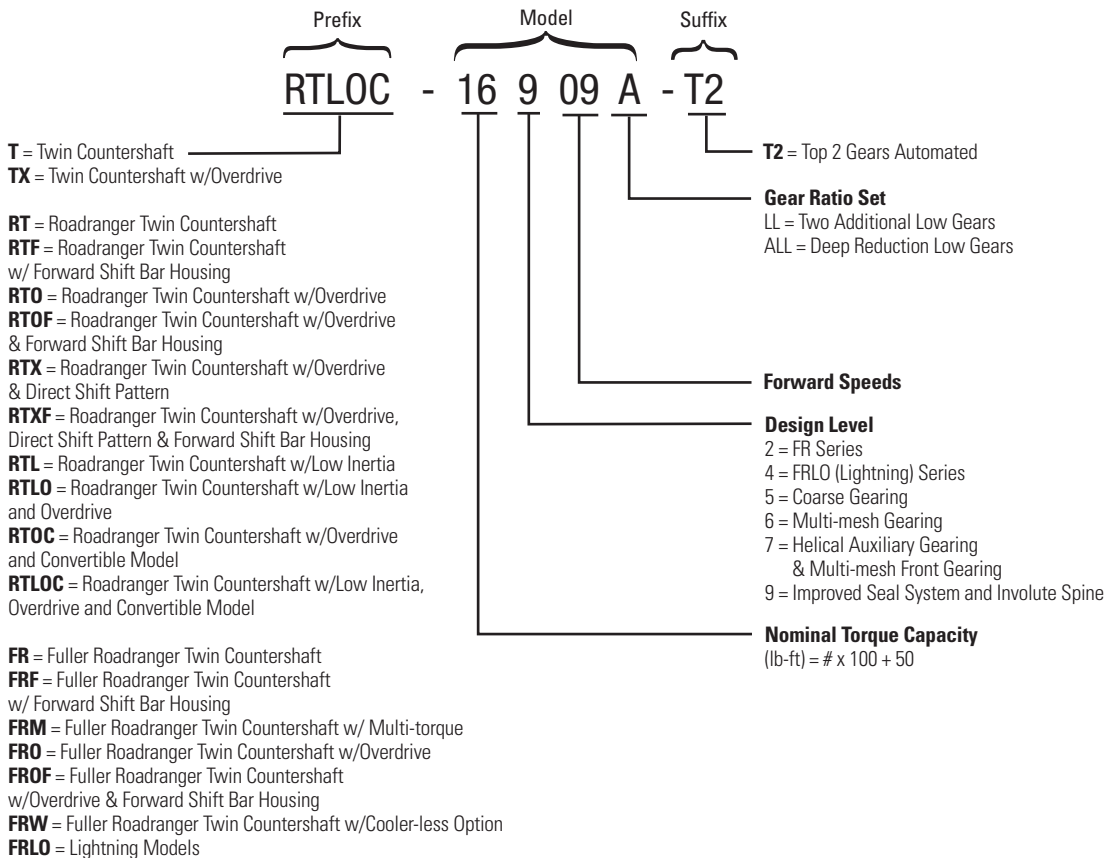

Manual Transmissions – Medium-Duty

(old nomenclature rules)

Marketing Name: Fuller 6-Speed Manual Transmission

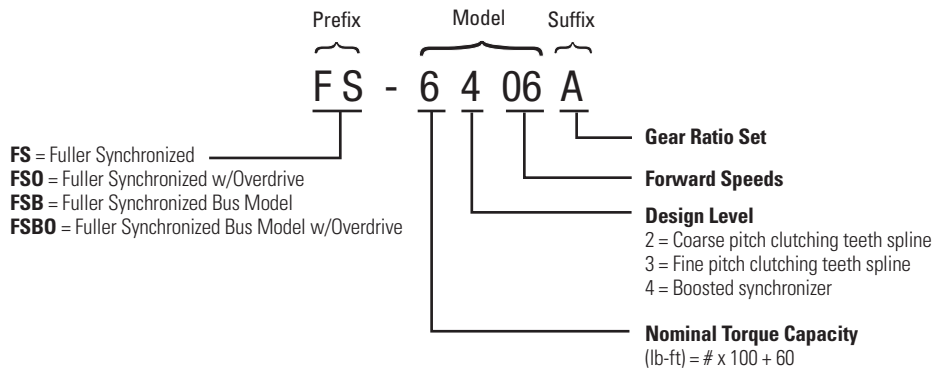

Hybrid Power Systems

Marketing Name: Eaton Hybrid City Delivery (CD)

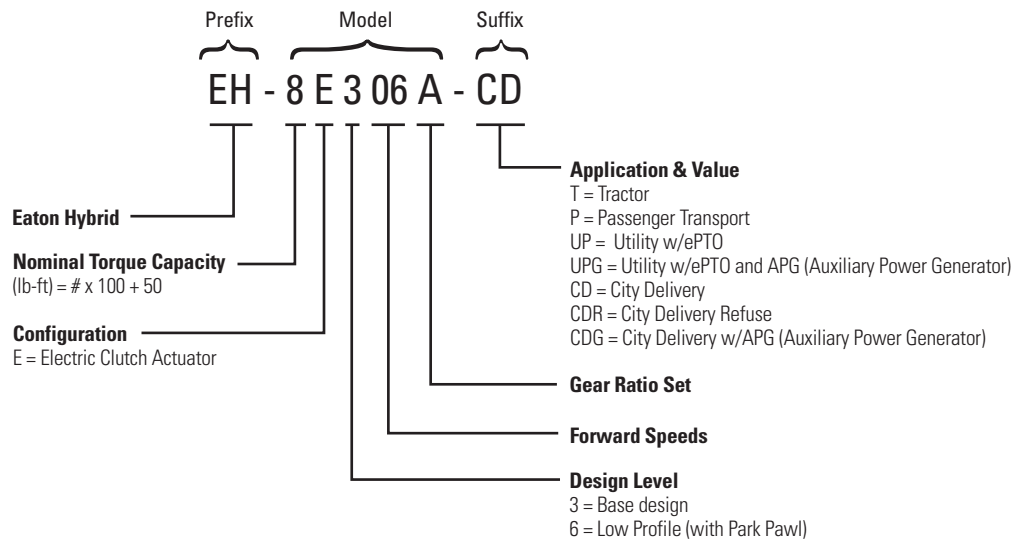

Clutch

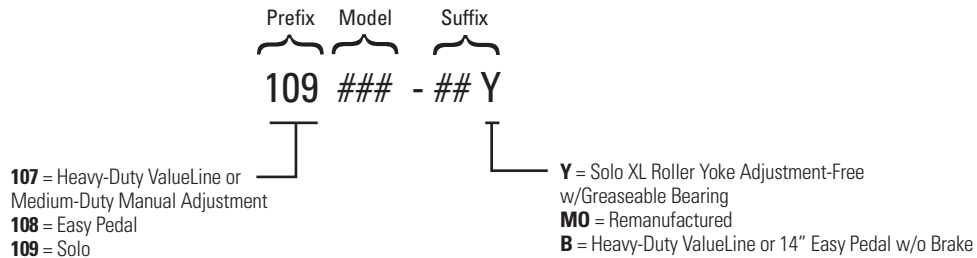

Tandem Drive Axle

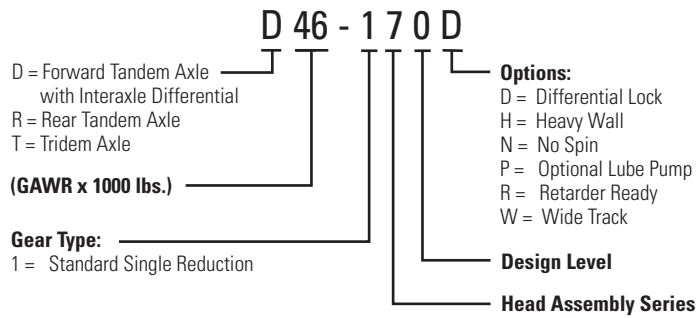
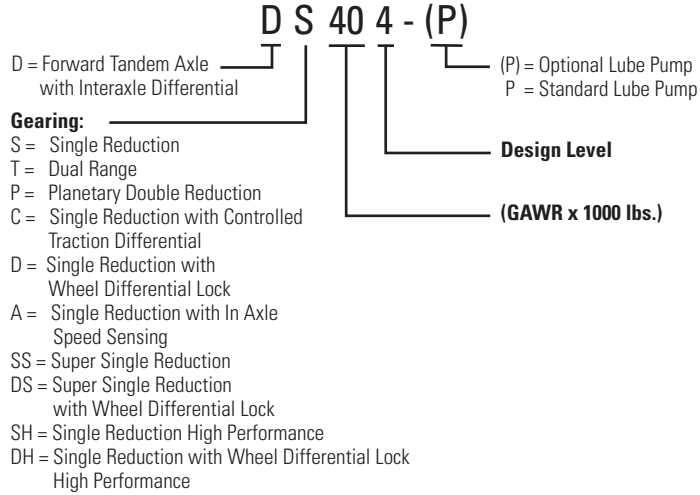

Single Drive Axle

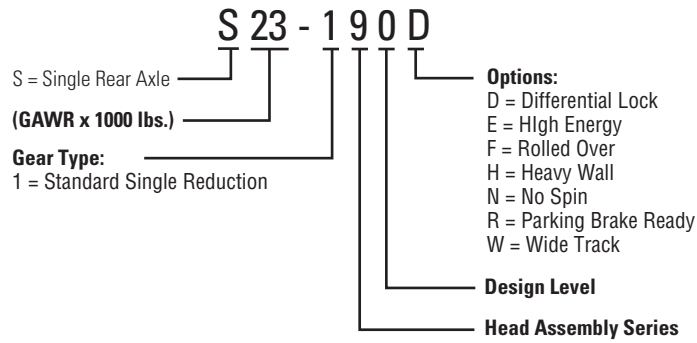
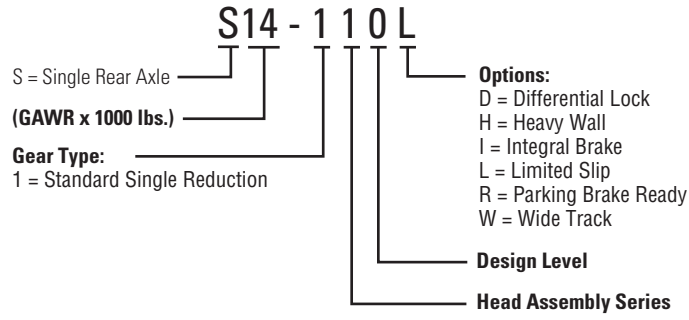
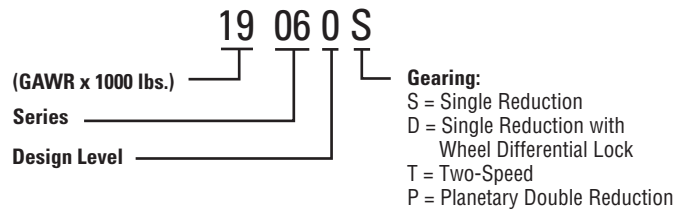

Steer Axle

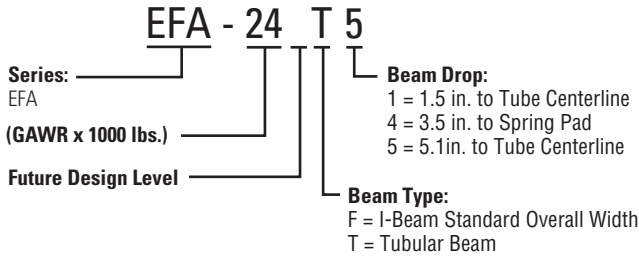
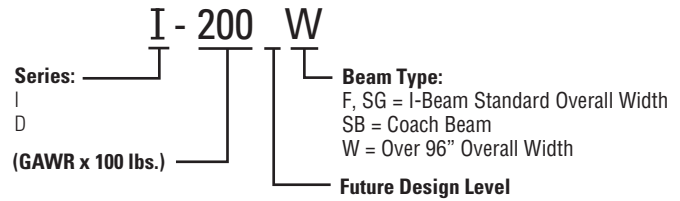
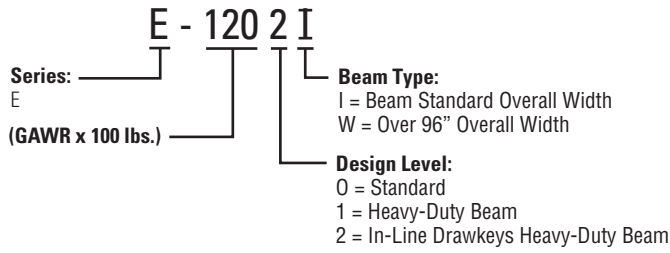

Brake

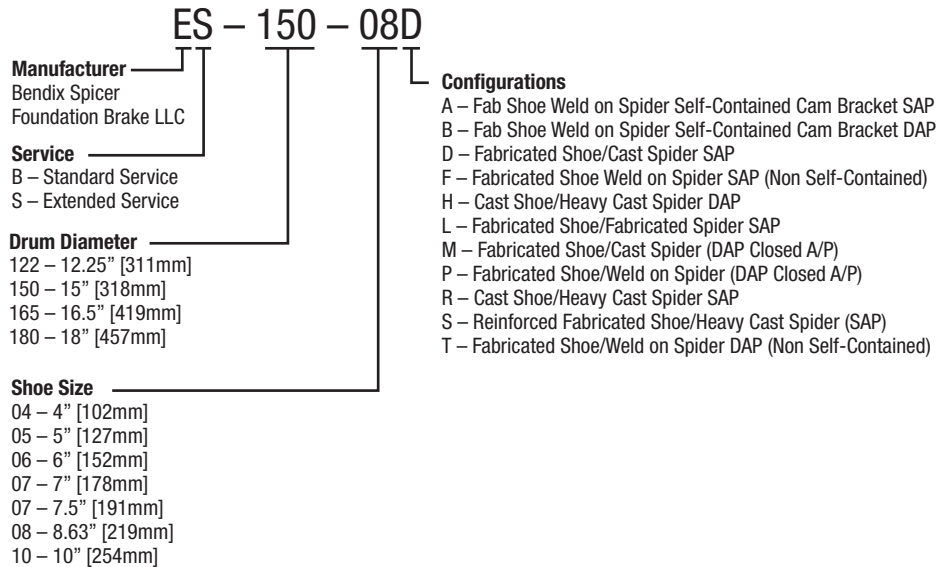

Please reference the Roadranger Spec Guide, item RRSL0001, or visit www.roadranger.com

Roadranger®



For spec'ing or service assistance, call 1-800-826-HELP (4357) or visit our web site at www.roadranger.com. In Mexico, call 001-800-826-4357.

Roadranger: Eaton, Dana and other trusted partners providing the best products and services in the industry, ensuring more time on the road.